

Mini Ringlight



Annular mini Ringlight

Features

- Continuous ring of illumination fiber within the housing.
- Mounts directly to objective by means of thumb screw.
- Optimized illumination of the mini ringlight only requires a comparably small fiber bundle diameter.
- Therefore the SCHOTT mini ringlight has an interchangeable adaptor with removable ferrules, which allows the connection to all KL light sources.

Benefits

- Absolute shadow-free illumination.
- Small dimensions for easy handling.

Cold light source**	Part No.	Type	Length	Inner Ø	Outer Ø	Height	Minimum working distance*	Active Ø branch	Outer Ø Jacketing
			(L)	(ID)	(OD)	(H)	(A)	(b)	(D)
KL 300 LED KL 1600 LED KL 2500 LED KL 1500 HAL KL 2500 LCD	157 040	Slit-RL 40 mm Ø	1000 mm 39.37"	40 mm 1.58"	64 mm 2.52"	24 mm 0.95"	15 mm 0.58"	7 mm 0.28"	11.8 mm 0.47"

* Ringlight usable in any working distance above given minimum values.

** and discontinued KL 1500 products (KL 1500 compact, KL 1500 LCD, KL 1500 LED, KL 1500 LED Plus)

Mini Ringlight

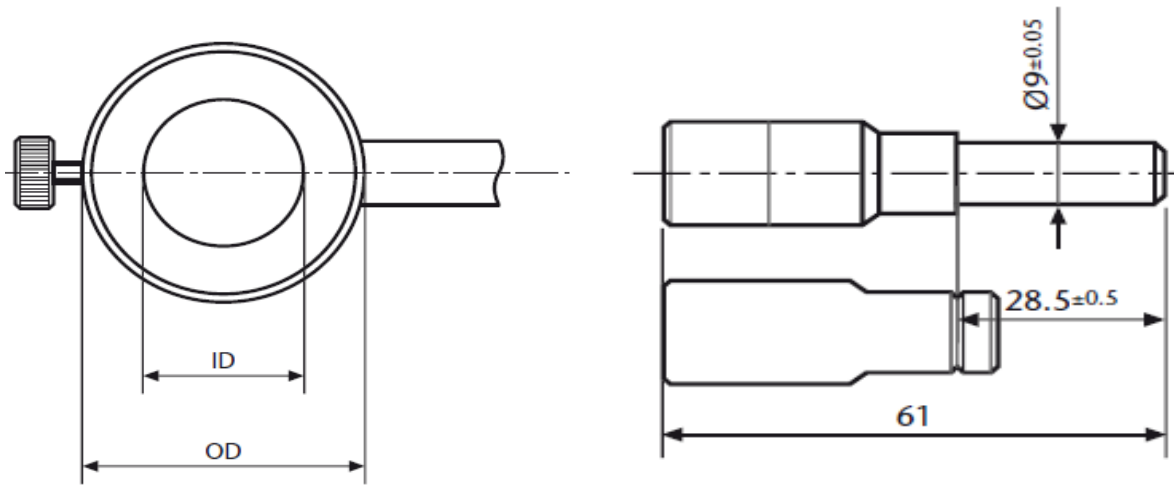
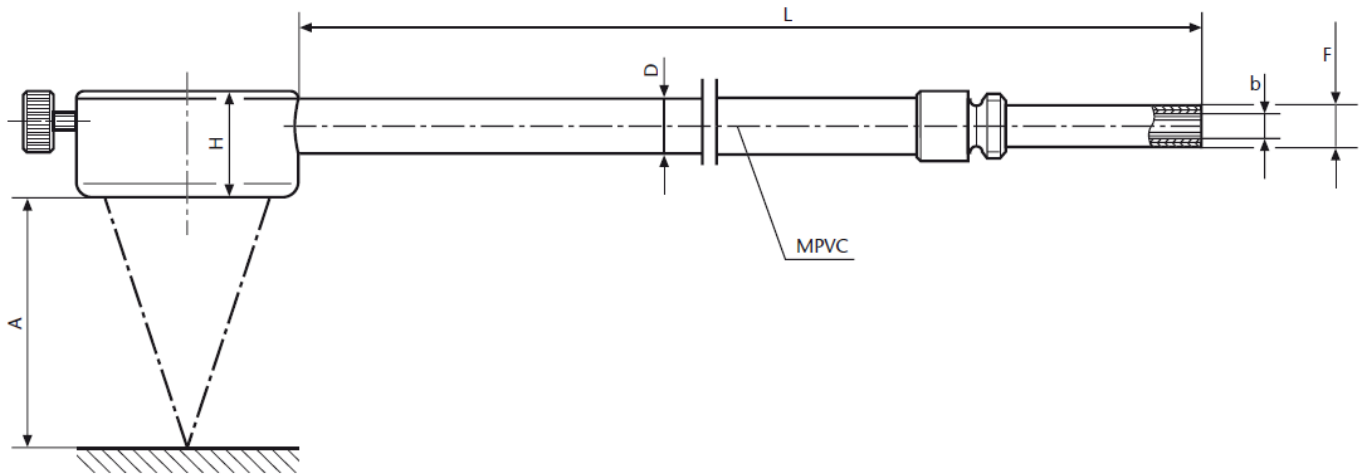

All specifications are subject to change without prior notice. This datasheet or any extracts thereof may only be used in other publications with express permission of SCHOTT. © SCHOTT AG

SCHOTT
Authorised Distributor
 Silicon Connection Pte Ltd
 Blk 7 Kallang Place
 #05-01/05/07/11/12
 Singapore 339153
 Phone: +65 81861235
 steven@si-cnx.com
www.si-cnx.com/products/lighting-imaging/

